

ABSTRACT

The effective utilization of the solar panel and the constant power for small system to big energy system is required. A circuit based simulation model for a PV cell for estimating the IV characteristic curves of photovoltaic panel with respect to changes on environmental parameters (temperature and irradiance) and cell parameters. The simulation and modeling of the solar panel is the initial point to enter in the research related to the solar energy system. The power output is highly depending on the environment condition and solar radiation. Photovoltaic systems require interfacing power converters between the PV arrays and the use cuk converter.

KEYWORDS: Pv module, Solar cell, cuk Converter, etc.

INTRODUCTION

The conversion of solar energy into electric energy is performed by means of photovoltaic (PV) generators. Photovoltaic offer the highest versatility among renewable energy technologies. Electricity produced from photovoltaic (PV) systems has a far smaller impact on the environment than traditional methods of electrical generation. The most attractive features of solar panels are the nonexistence of movable parts, the very slow degradation of the sealed solar cells and the extreme simplicity of its use and maintenance. Another advantage is the modularity. All desired generator sizes can be realized, from the mill watt range to the megawatt range. Solar energy is a pollution-free source of abundant power. During their operation, PV cells need no fuel, an give off no atmospheric or water pollutants and require no cooling water. The use of PV systems is not constrained by material or land shortages and the sun is a virtually endless energy source.

Worldwide energy consumption has increase The photovoltaic (PV) cell is basically a p-n junction fabricated in a thin wafer of semiconductor. The solar energy is directly converted to electricity through photovoltaic effect. PV cell exhibits a nonlinear P-V and I-V characteristics which vary with cell temperature (T) and solar irradiance (S). Different equivalent circuit models of PV cell have been discussed in literature. The system performance can be optimized by connecting the pv model with buck-boost converter.

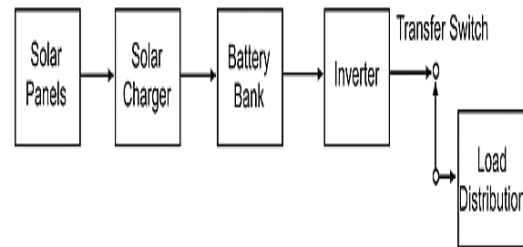

Fig: 1 Solar system module

Solar powered electrical generation relies on photovoltaic system and heat engines. The solar energy's uses are limited only by human creativity. To harvest the solar energy, the most common way is to use photo voltaic panels which will receive photon energy from sun and convert to electrical energy source. Solar technologies are broadly classified as either passive solar or active solar depending on the way they detain, convert and distribute solar energy. Solar energy is abundantly available that has made it possible to harvest it and utilize it properly. A solar energy can be a standalone generating unit or can be a grid connected generating unit depending on the availability of a grid nearby. Thus it can be used to power rural areas where the availability of grids is very low.

PHOTOVOLTAIC

A Photovoltaic (PV) system directly converts solar energy into electrical energy source. The basic device of a PV system is the PV cell. In the cells may be grouped to form arrays. In the voltage and current available at the terminals of a PV device may directly feed small loads such as lighting systems and DC motors by using proper energy conversion. This photovoltaic system consists of main parts such as PV module, battery, charger, inverter and load.

Equivalent model

A Photovoltaic cell is a device used to convert solar radiation directly into electricity signal. It consists of two or more thin layers of semiconducting material, and most commonly silicon. When the silicon is exposed to light , electrical charges are generated. PV cell is usually represented by an electrical equivalent one-diode model shown in fig.2.

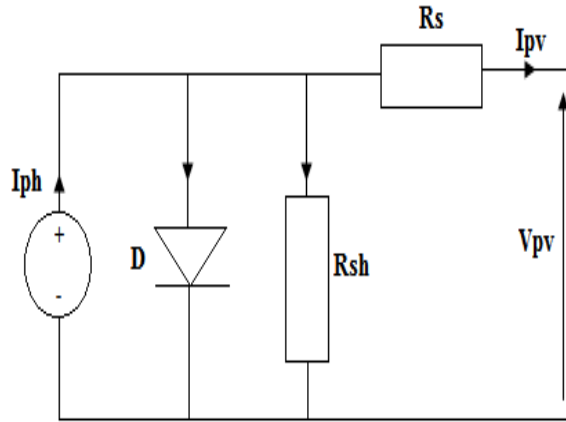

Fig: 2 Photovoltaic cell modeling as diode circuit

The current source I_{ph} represents the cell photocurrent. In usually the value of R_{sh} is very large and that of R_s is very small signal, hence they may be neglected to simplify the analysis. The photovoltaic (PV) cells are grouped in larger units called PV modules which are further interconnected in a parallel-series configuration to form PV arrays.

Modeling photo-current

$$I_{ph} = [I_{scr} + K_i i(T - 298)] * \lambda / 1000 \quad (1)$$

Module reverse saturation current – I_{rs}

$$I_{rs} = I_{scr} / [\exp\left(\frac{qV_{oc}}{N_s kAT}\right) - 1] \quad (2)$$

The module saturation current I_0 varies with the cell which is given by

$$I_0 = I_{rs} \left[\frac{T}{T_r}\right]^3 \exp\left[\frac{q * E_{g0}}{Bk} \left\{\frac{1}{T_r} - \frac{1}{T}\right\}\right] \quad (3)$$

$$I_{pv} = N_p * I_{ph} - N_p * I_0 \left[\exp\left\{\frac{q * (V_{pv} + I_{pv} R_s)}{N_s kAT}\right\} - 1\right] \quad (4)$$

Where $V_{pv} = V_{oc}$, $N_p = 1$ and $N_s = 36$

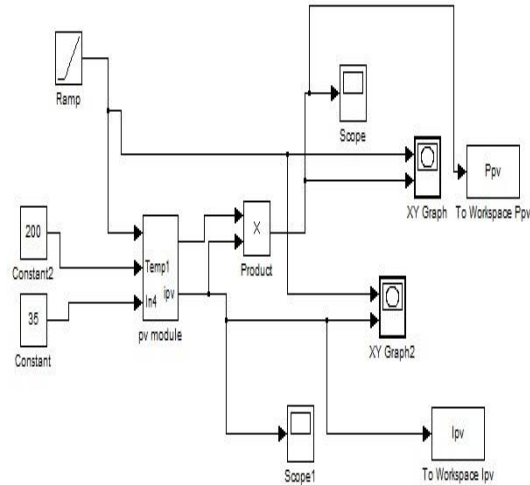

Fig: 3 Simulation pv model

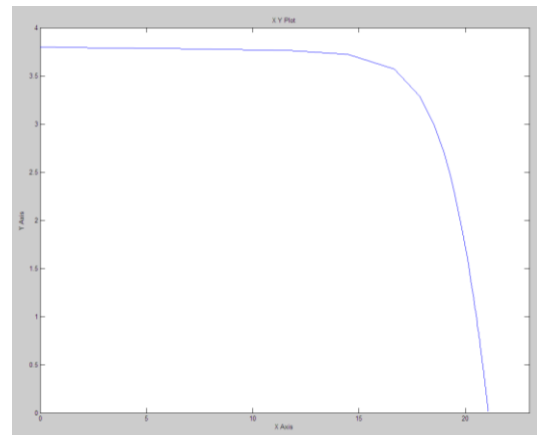

Fig: 4 Characteristic for PV

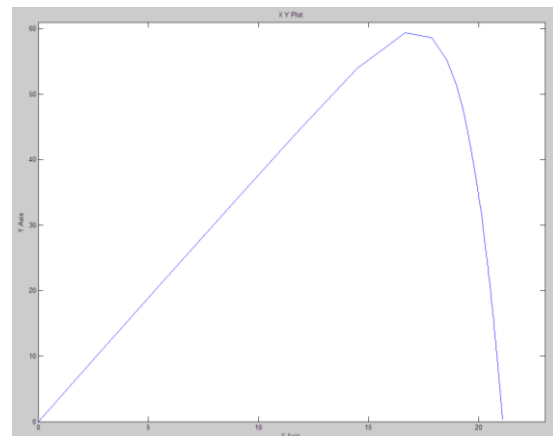

Fig: 5 P-V curve

Cuk Converter Modeling

There are variations on the basic Cuk converter. For example, the coils may share single magnetic core, which drops the output ripple, and adds efficiency. Because the power transfer flows continuously via the capacitor, this type of switcher has minimized EMI radiation. The Cuk converter enables the energy flow bidirectionally, by adding a diode and a switch. The basic circuit of a Cuk converter is shown in Fig.1 and as you can see it has an additional inductor and capacitor. The circuit configuration is in some ways like a combination of the buck and boost converters, although like the buck-boost circuit. It delivers an inverted output. Note that virtually all of the output current must pass through C1, and as ripple current. So C1 is usually a large electrolytic with a high ripple current rating and low ESR (equivalent series resistance), to minimize losses. When switch is turned on, current flows from the input source through L1 and MOSFET, storing energy in L1. Magnetic field. Then when MOSFET is turned off, the voltage across L1 reverses to maintain current flow.

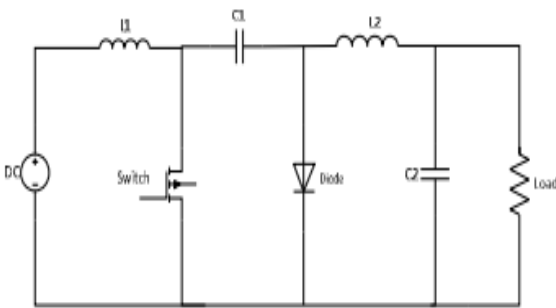

Fig: 6 cuk converter

As in the boost converter current then flows from the input source, through L1 and diode, charging up C1 to a voltage somewhat higher than Vin and transferring to it some of the energy that was stored in L1. Then when MOSFET is turned on again, C1 discharges through via L2 into the load, with L2 and C2 acting as a smoothing filter.

$$\frac{V_{out}}{V_{in}} = -\frac{D}{(D-1)} \quad (4)$$

RESULTS AND DISCUSSION

System description

In this paper, the simulation model is developed with MATLAB/SIMULINK. Simulation model of the proposed method is shown in Fig.7. The proposed circuit needs independent dc source which is supplied from photovoltaic cell (PV cell). The inputs are fed by voltage and current of the photovoltaic terminals, while the output provides duty cycle for the cuk converter.

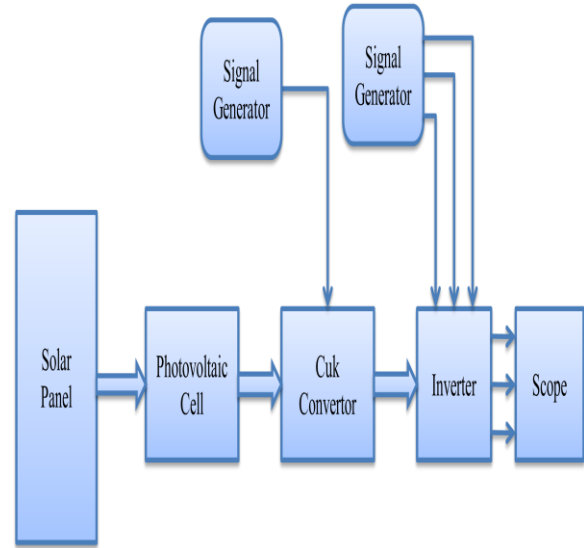

Fig: 7 Simulation of pv connected buck boost converter
The simulations were carried out in Simulink and the various voltages, currents and power plots were obtained.

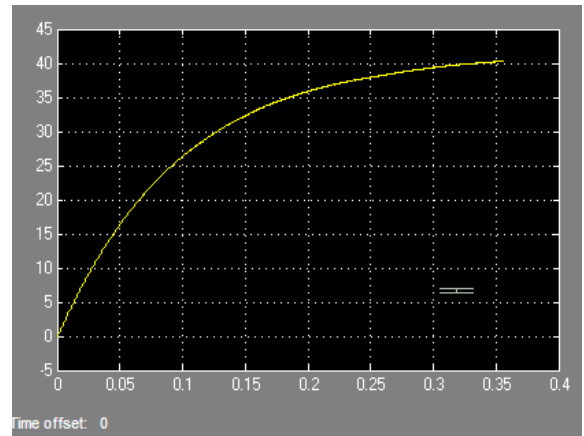

Fig: 8 Output Voltage for the cuk converter

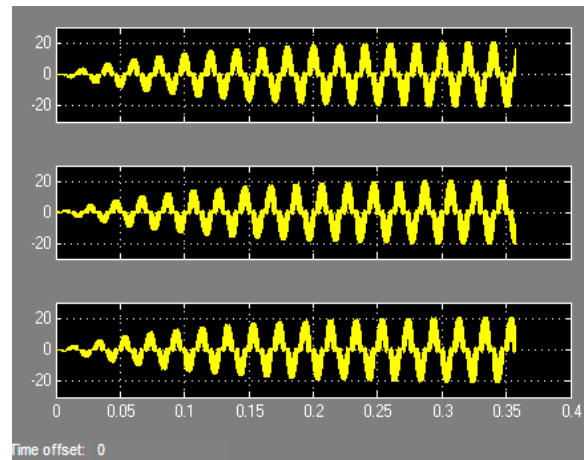

Fig: 9 Output Voltage for the three phase inverter

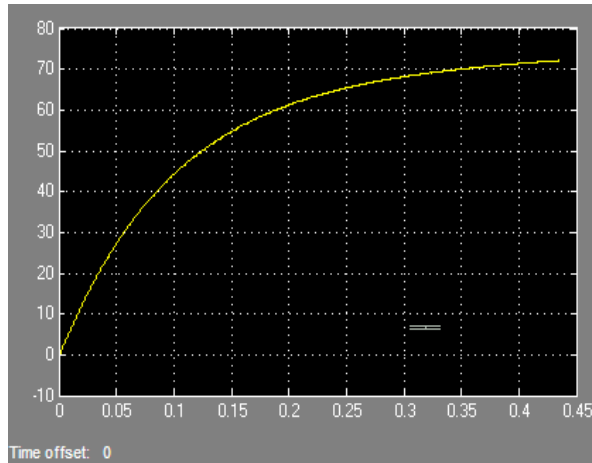

Fig: 10 Output Voltage for the cuk converter

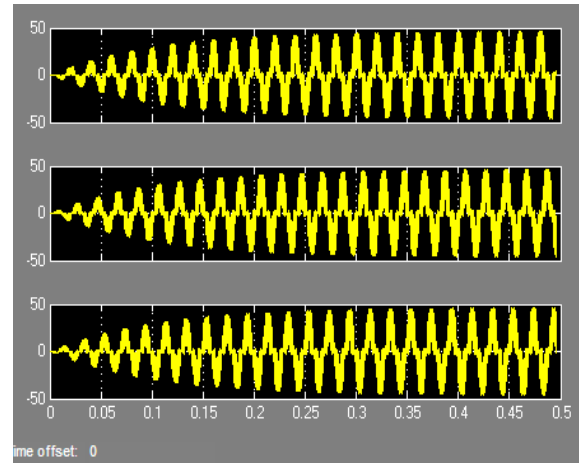

Fig: 13 Output Voltage for three phase inverter

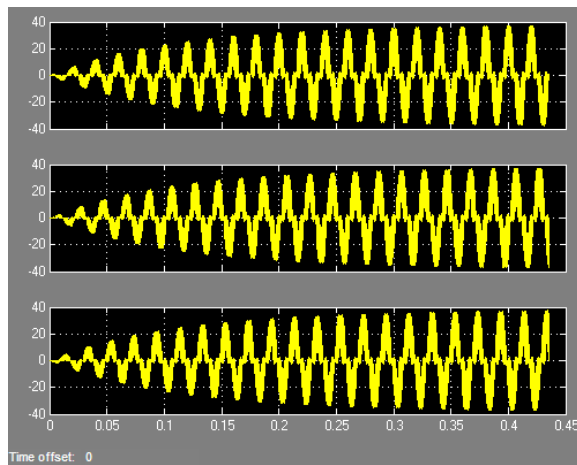

Fig: 11 Output Voltage for three phase inverter

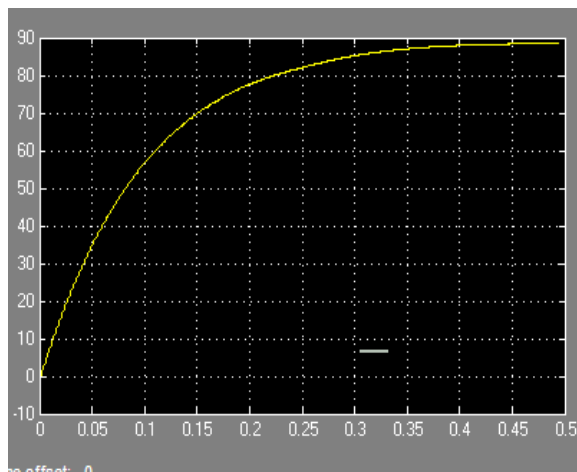

Fig: 12 Output Voltage Increase for the cuk converter

CONCLUSION

In this paper, Cuk converter is simulated using MATLAB. Cuk converter, the duty cycle is varied and corresponding voltage and current is observed. It is used different duty cycle, the performance of converter is better results. At this duty cycle, the output power of Cuk converter is maximum.

REFERENCES

- [1] Lipika Nanda, Sushree Sibani Das, "Convergence of pv system with Buck-Boost Converter using MPPT Techniques", *International Journal of Engineering and Computer Science*, Volume 2 Issue 11 November, 2013.
- [2] Shiba arora, pankaj sharma, "Modelling & Simulation of Photovoltaic system to optimize the power output using Buck-Boost Converter", *International Journal of Information Technology and Electrical Engineering*, June 2014.
- [3] M.S.Sivagamasundari, Dr.P.Melba Mary, V.K.Velvizhi, "Maximum Power Point Tracking For Photovoltaic System by Perturb and Observe Method Using Buck Boost Converter", *International Journal of Advanced Research in Electrical, Electronics and Instrumentation Engineering* Vol. 2, Issue 6, June 2013.
- [4] N. Pandiarajan and Ranganath Muthu, "Mathematical Modeling of Photovoltaic Module with Simulink", *International Conference on Electrical Energy Systems (ICEES 2011)*, 3-5 Jan 2011.
- [5] P.Sudeepika, G.Md. Gayaz Khan, "Analysis of Mathematical Model Of PV Cell Module in Matlab/Simulink Environment", *International Journal of Advanced Research*

*in Electrical, Electronics and
Instrumentation Engineering, Vol. 3, Issue
3, March 2014.*